



Rewarding Learning

General Certificate of Secondary Education
2018

Centre Number

--	--	--	--	--

Candidate Number

--	--	--	--

Biology

Unit 1

Higher Tier

MV18

[GBL12]

FRIDAY 8 JUNE, MORNING

Time

1 hour 15 minutes, plus your additional time allowance.

Instructions to Candidates

Write your Centre Number and Candidate Number in the spaces provided at the top of this page.

You must answer the questions in the spaces provided.

Do not write on blank pages.

Complete in black ink only.

Answer **all ten** questions.

Information for Candidates

The total mark for this paper is **75**.

Figures in brackets printed at the end of each question indicate the marks awarded to each question or part question.

Quality of written communication will be assessed in Question **10**.

1 (a) A plant seedling received bright light from one side.

The diagram shows the plant seedling at the start and after 24 hours.

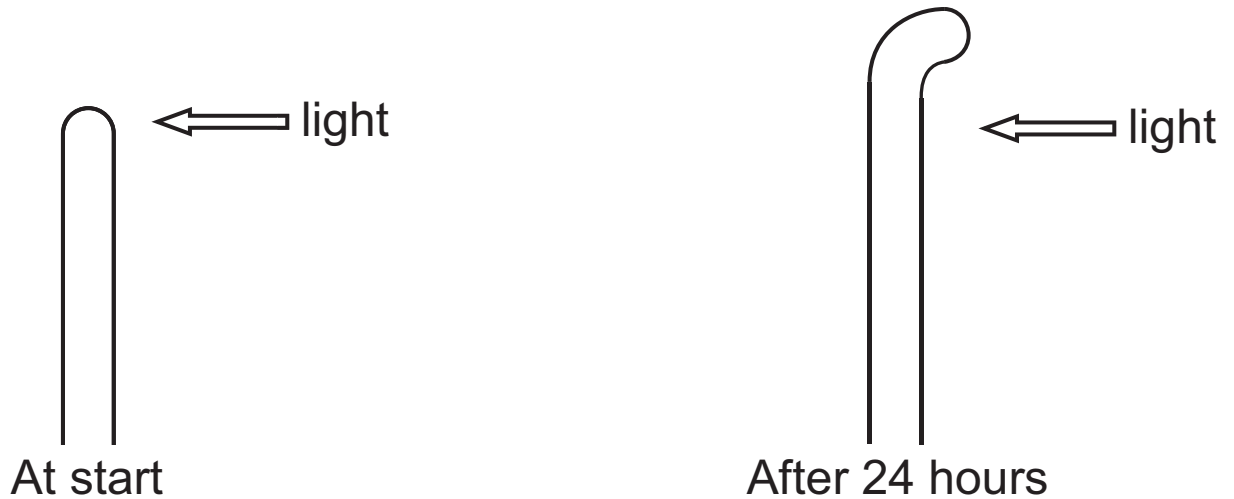

Look at the diagram.

(i) Name this response to light. [1 mark]

(ii) Name the plant hormone which brings about this response. [1 mark]

(iii) Explain how this response is brought about.
[2 marks]

(b) Explain the advantage of this response to the plant seedling. [2 marks]

2 The following sentences give information about feeding relationships.

Grass is a producer.

Rabbits, slugs and insects are primary consumers.

Frogs and thrushes eat insects.

Thrushes also eat slugs.

Hawks are predators of thrushes and frogs.

Foxes eat rabbits and frogs.

(a) Use the information in the sentences to **complete the food web**. [3 marks]

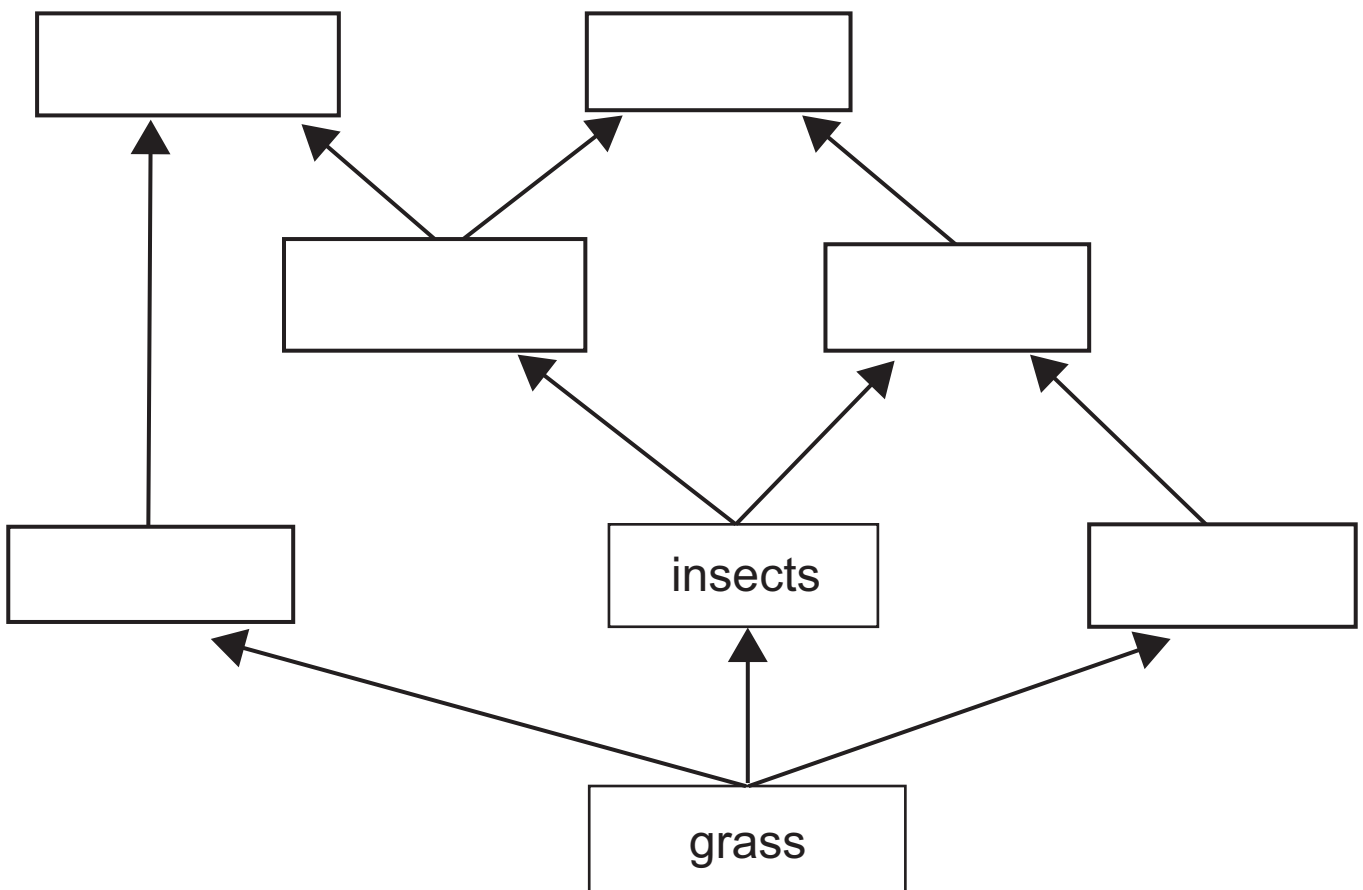

(b) What is the source of energy in this food web?
[1 mark]

(c) Name an animal that feeds at **two** trophic levels in this food web. [1 mark]

(d) What do the arrows in the food web represent?
[1 mark]

(e) What is the role of a producer in a food web?
[2 marks]

4 Stem cells are found in animals and plants.

(a) Give **two** ways stem cells differ from other body cells.
[1 mark for each]

1. _____

2. _____

(b) (i) Give **one** source of adult stem cells. [1 mark]

(ii) Embryonic stem cells have a much greater potential in the development of medical treatments than adult stem cells.

Explain why. [1 mark]

(c) In plants, stem cells are found in the growing points at the end of shoots and roots.

Give the term used to describe these growing points.
[1 mark]

5 The graph shows the effects of three environmental factors on the rate of photosynthesis of tomato plants in a greenhouse.

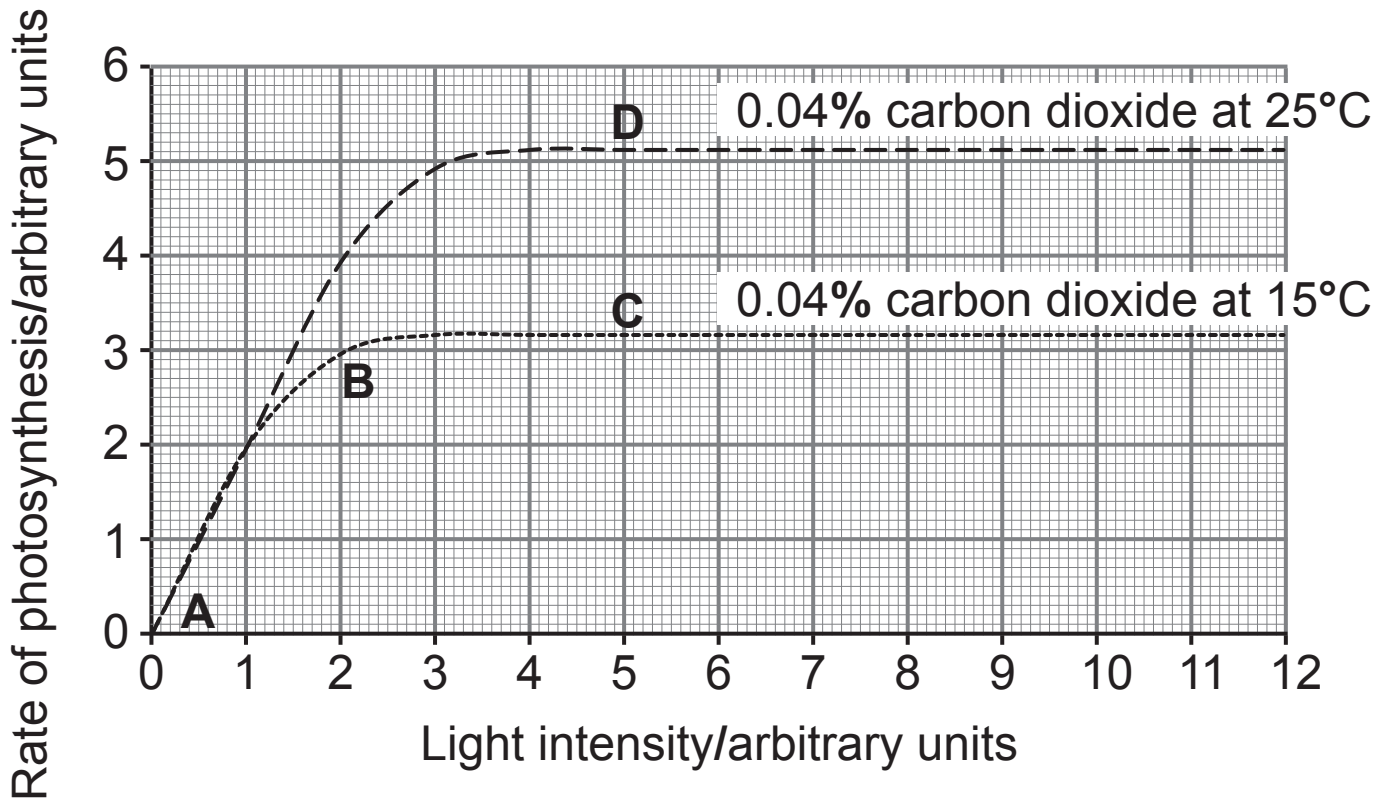

(a) Describe and explain the shape of the graph between **A** and **B**. [2 marks]

(b) Explain why the rate of photosynthesis is higher at **D** than at **C**. [2 marks]

- 6 (a) The diagram shows apparatus students set up to investigate diffusion.

The students used three different concentrations of ammonia solution.

The investigation was carried out in a fume cupboard.

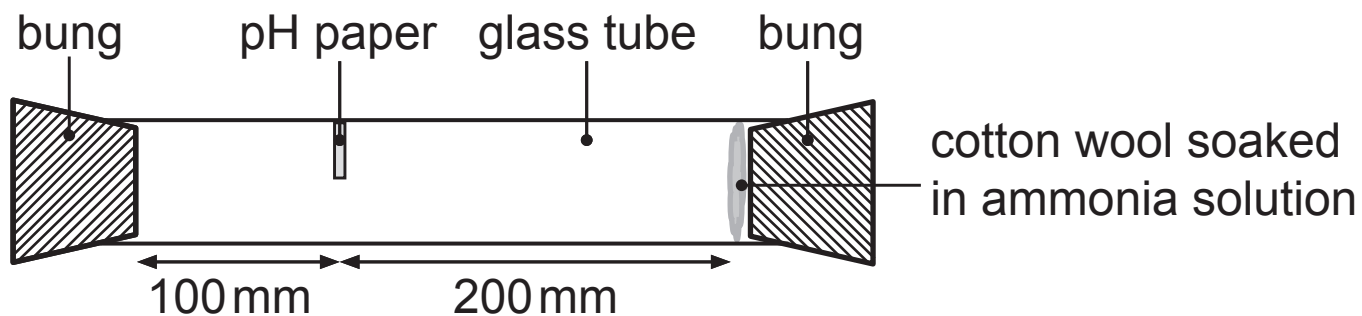

The students soaked a piece of cotton wool in ammonia solution and placed it at one end of the glass tube.

Ammonia causes the pH paper to turn blue.

The students recorded the time taken for the pH paper to turn blue.

They repeated the investigation three times for each concentration of ammonia solution.

The table shows their results.

Concentration of ammonia solution /M	Time for pH paper to turn blue/s				Average rate of diffusion /mm s ⁻¹
	1	2	3	Average	
1	422	401	404	409	0.49
3	331	316	352	333	0.60
5	256	243	251		

- (i) Calculate the **average time** for the pH paper to turn blue with the 5M ammonia solution. [1 mark]

_____ s

- (ii) Use the equation below to calculate the average rate of diffusion for the 5M ammonia solution. [2 marks]

$$\text{Average rate of diffusion (mm s}^{-1}\text{)} = \frac{\text{distance (mm)}}{\text{average time (s)}}$$

Show your working.

_____ mm s⁻¹

(iii) Describe and explain the effect of concentration on the average rate of diffusion. [3 marks]
Use data from the table on page 11 to support your answer.

A second group of students investigated the diffusion of iodine solution through starch agar jelly at **10°C**.

They placed iodine solution in a hole at the centre of the starch agar jelly at the start of the experiment.

The diagram shows their experimental setup.

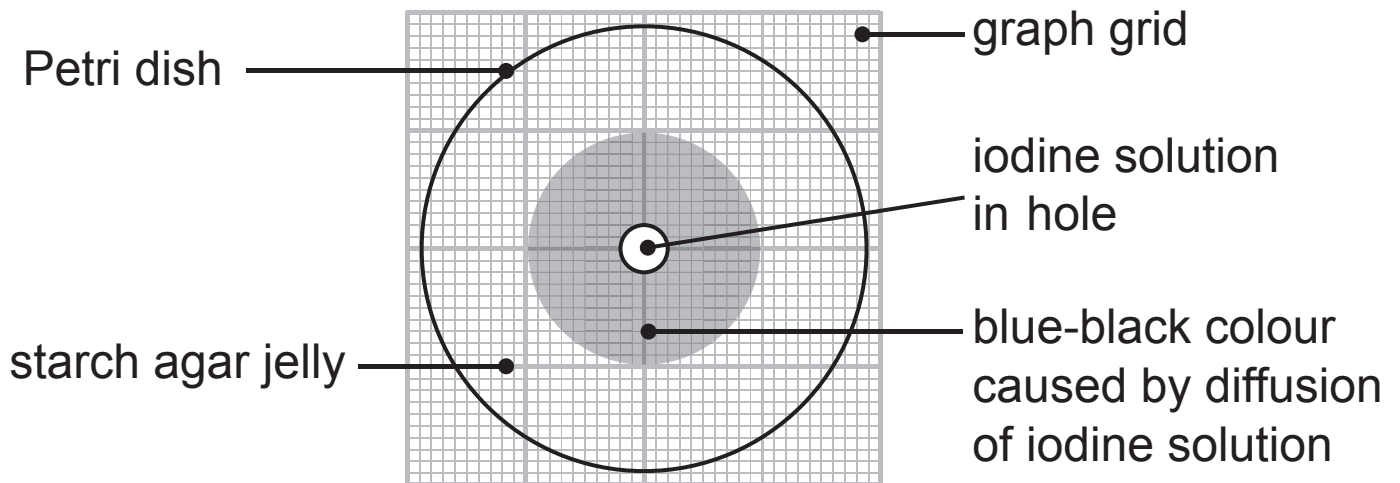

These students recorded the time taken for the blue-black colour to reach the size shown in the diagram.

They repeated the experiment at **20°C**.

(b) Suggest how this increase in temperature would affect the time taken for the blue-black colour to reach the same size. [2 marks]

Explain your answer.

7 The ileum is adapted for absorption by having villi which provide a large surface area.

(a) Give **two other** ways the ileum is adapted to provide a large surface area. [1 mark for each]

1. _____

2. _____

(b) The diagrams show normal and diseased villi from the ileum.

The diagrams are drawn to the same scale.

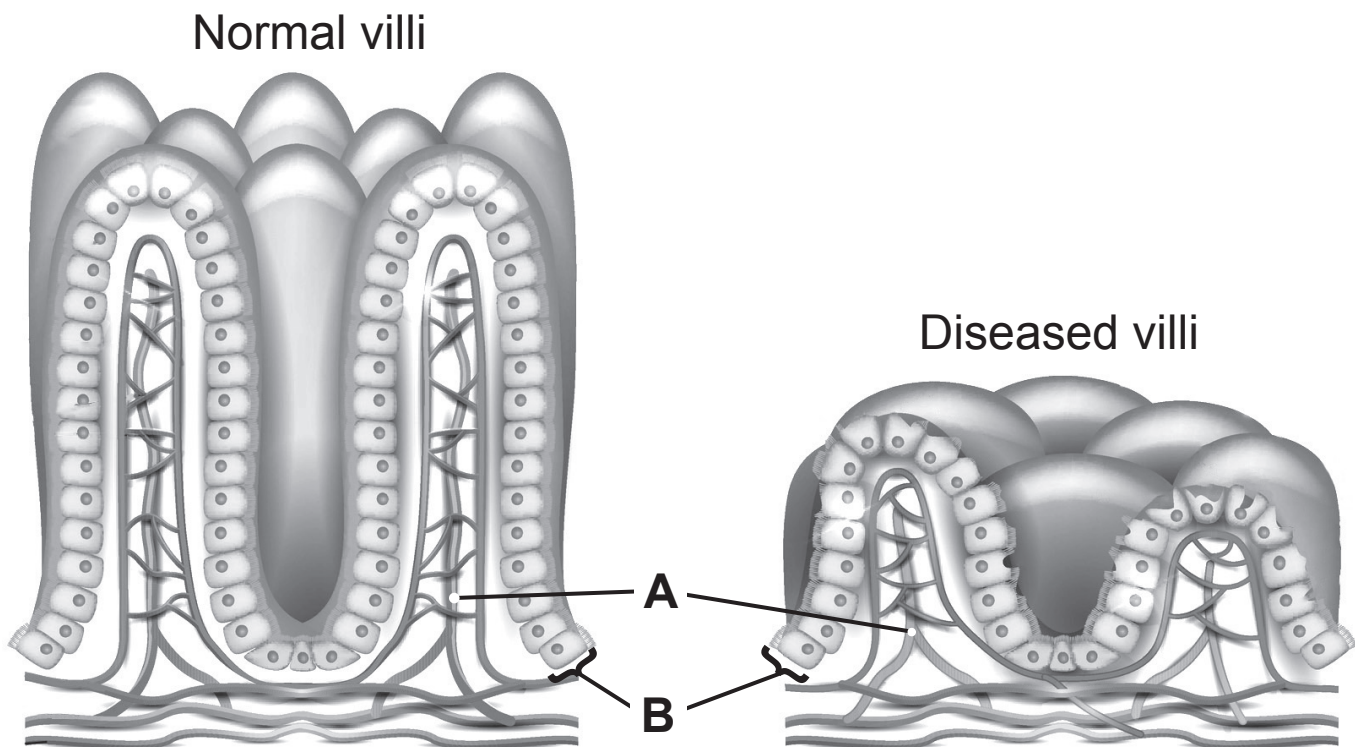

(i) Name part **A** and describe its role in the absorption of digested food molecules. [1 mark for each]

Name _____

Role _____

(ii) Describe and explain how layer **B** helps in the absorption of digested food molecules. [2 marks]

(c) Describe how the disease has changed the structure of the villi and suggest how this would affect their function. [3 marks]

- 8 (a) Graph A shows the carbon dioxide concentration in the atmosphere in parts per million (ppm) from 2000 to 2015.

Graph A

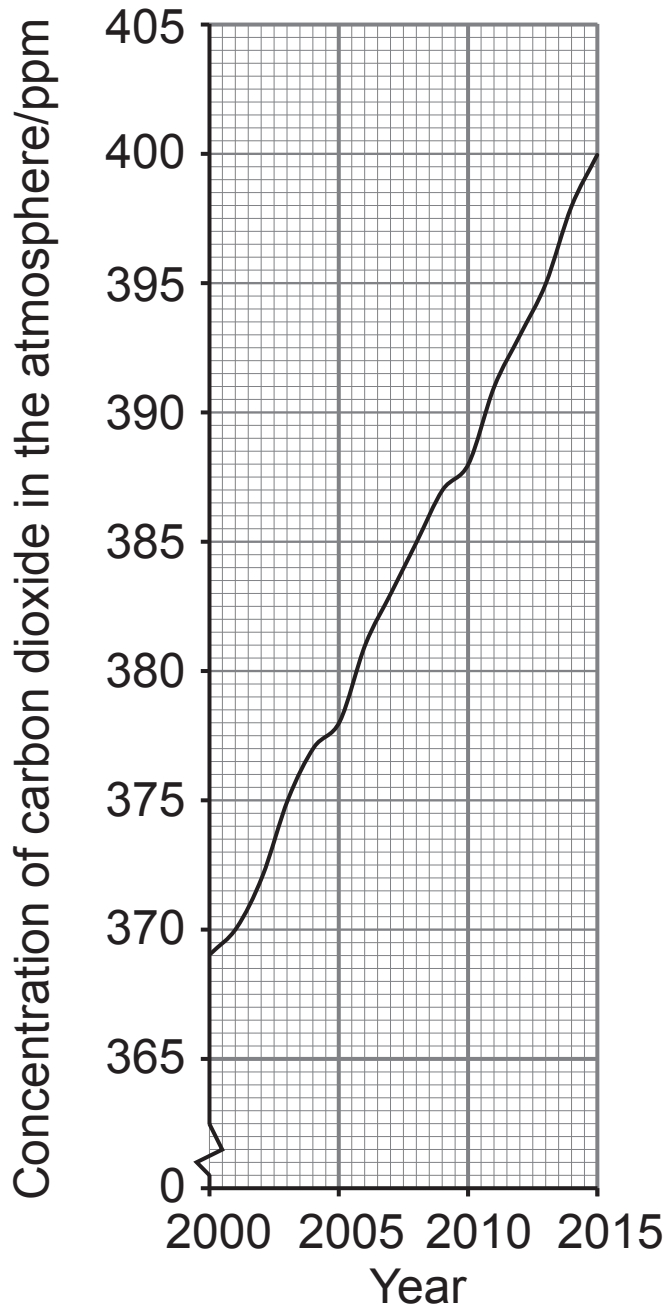

- (i) Calculate the percentage change of the carbon dioxide concentration in the atmosphere between 2000 and 2015 from the graph on page 16. [2 marks]

Show your working.

Carbon dioxide concentration in the atmosphere has changed between 2000 and 2015.

- (ii) Explain how deforestation has contributed to this change in carbon dioxide concentration. [3 marks]

(b) Graph **B** shows the area of Arctic sea ice in March and September in each year from 2000 to 2015.

Graph **B**

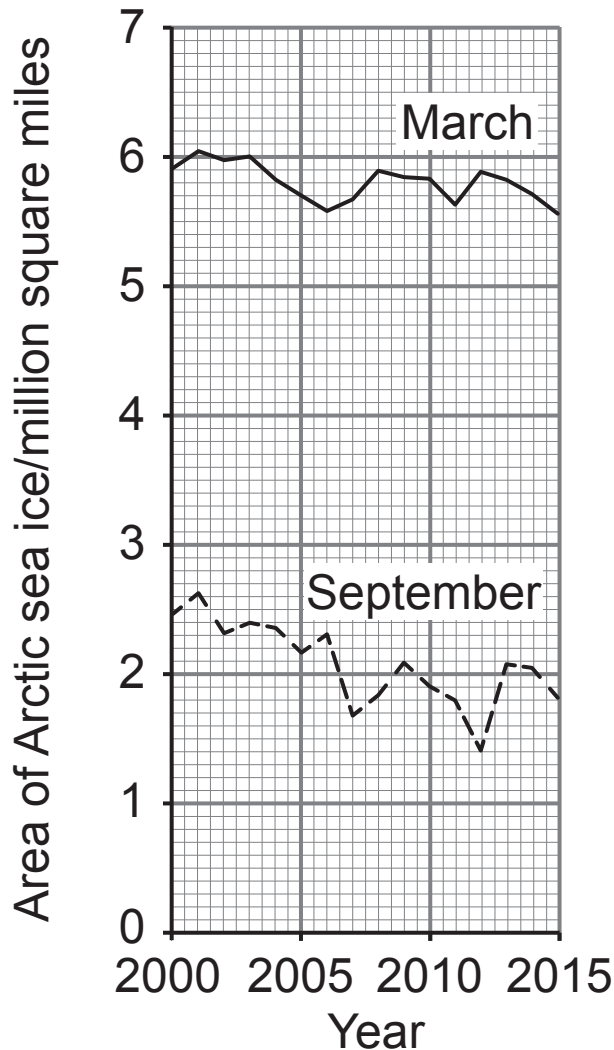

Describe **one** similarity between the overall trends in March and September from 2000 to 2015. [1 mark]

(c) Explain how the change in carbon dioxide concentration in graph **A** on page 16 is linked to the changes in the area of Arctic sea ice between 2000 and 2015 in graph **B** on page 18. [3 marks]

9 (a) The diagram shows a reflex arc.

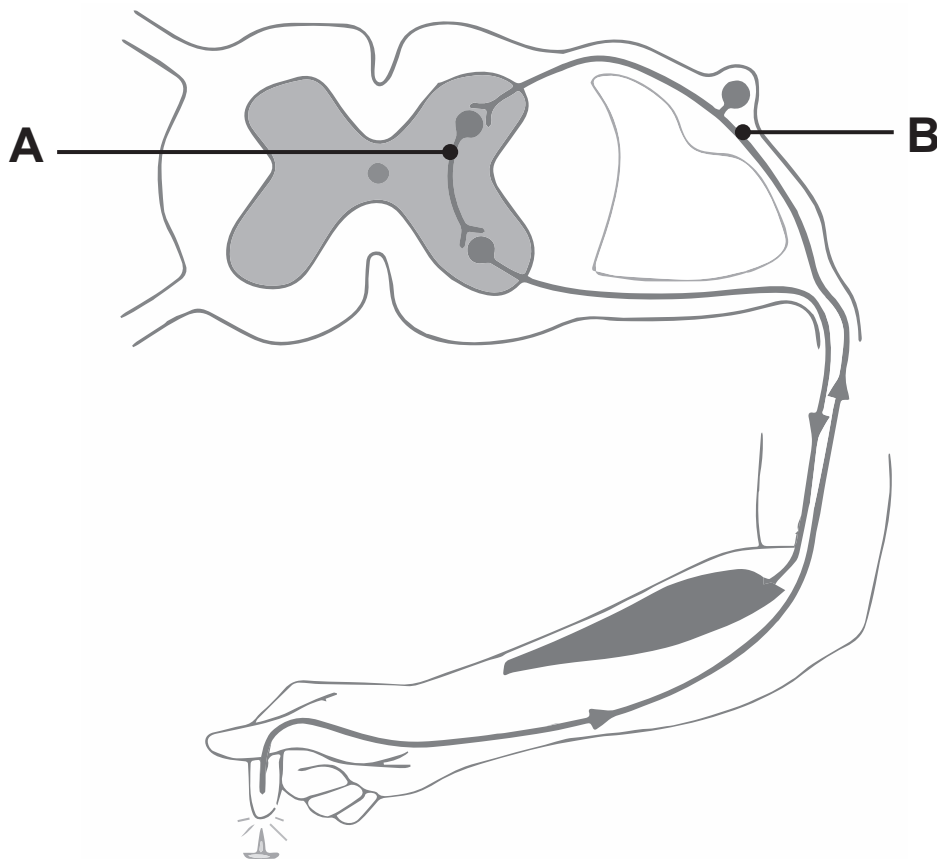

(i) Name neurones **A** and **B**. [1 mark for each]

A _____

B _____

(ii) Give **two** differences between an involuntary reflex action and a voluntary action. [1 mark for each]

1. _____

2. _____

10 (a) Farmers apply fertilisers to increase the growth of grass.

Slurry is a mixture of faeces and urine from the farm animals which is used as fertiliser.

Farmers grow clover plants because they carry out nitrogen fixation.

The table gives some information about farming in **three** fields in County Tyrone.

Field	Crop	Fertiliser	Percentage of air in the soil
A	grass	slurry	32
B	grass and clover mix	slurry	39
C	grass	artificial fertiliser	16

Use the information in the table to help answer the following questions.

(i) Suggest which field **A**, **B** or **C** is most likely to become waterlogged after heavy rain. [1 mark]

Explain your answer. [1 mark]

Field _____

Explanation _____

Waterlogged soils contain increased numbers of denitrifying bacteria.

(ii) Describe and explain how increased numbers of denitrifying bacteria affect the growth of grass in waterlogged soils. [3 marks]

THIS IS THE END OF THE QUESTION PAPER

SOURCES

Q2(a) Source: *Principal Examiner*

Q5. Source: *Chief Examiner*

Q7(b). . . . © *Tefi / Shutterstock.com*

Q8(a) © *National Oceanic and Atmospheric Administration. Earth System Research Laboratory*

Q8(b) © *United States Environmental Protection Agency*

Q9(a) © *Barking Dog Art*

For Examiner's use only	
Question Number	Marks
1	
2	
3	
4	
5	
6	
7	
8	
9	
10	

Total Marks	
--------------------	--

Examiner Number

Permission to reproduce all copyright material has been applied for.
In some cases, efforts to contact copyright holders may have been unsuccessful and CCEA will be happy to rectify any omissions of acknowledgement in future if notified.